

External Assessment 2022

PHYSICAL SCIENCES

PSC315118

Section **A**

| | |
|-------------------|----|
| Pages | 12 |
| Questions | 5 |
| Information Sheet | 1 |

Preparation time for this exam: 15 minutes

Suggested working time: 36 minutes

Instructions:

- Answer **all** questions and **all** items within each question.
- Write your answers in the spaces provided in this exam paper.
 - Show working in answers to numerical questions and use appropriate units. Marks may not be given to answers without working.
 - Spare diagrams have been provided at the end of each section. Indicate in the box provided if you have used the spare diagrams.
- The exam is **three (3)** hours in length. It is suggested that you spend **approximately 36 minutes** in total answering the questions in this section.
- A TASC approved scientific calculator is allowed throughout the exam.
- The **Physical Sciences Information Sheet** can be used throughout the exam.
- All answers must be written in **English**.
- You **must** make sure your answers address:
 - Criterion 4 apply concepts and processes of atomic properties and nuclear reactions.

| Marker Use | |
|------------|------|
| C4 | / 36 |

Guide to Exam Structure

| | Questions available | Questions to answer | Suggested working time | Marks available |
|------------------|---------------------|---------------------|----------------------------------|------------------|
| Section A | 5 | 5 | 36 minutes | 36 marks |
| Section B | 5 | 5 | 36 minutes | 36 marks |
| Section C | 5 | 5 | 36 minutes | 36 marks |
| Section D | 5 | 5 | 36 minutes | 36 marks |
| Section E | 5 | 5 | 36 minutes | 36 marks |
| Totals | 25 | 25 | 180 minutes (3 hours) | 180 marks |

Question 1

- a) The image below is that of the atom Lithium-7, (${}^7_3\text{Li}$). Label the subatomic particles present in Lithium-7.

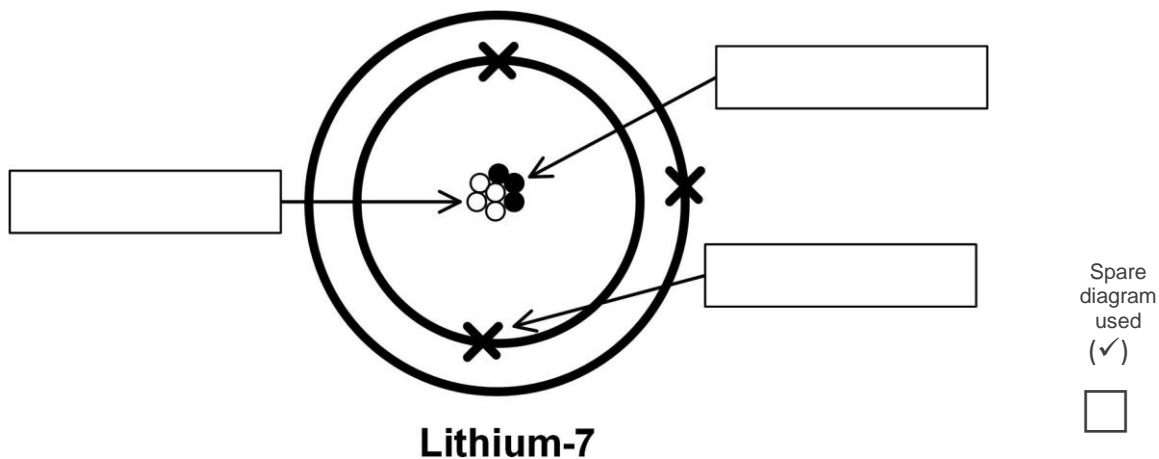

- b) Lithium readily forms a stable Li^+ ion. Why is Li^+ the most stable ion?

.....

.....

.....

.....

- c) Two other elements near lithium on the Periodic Table are beryllium and boron. Which of the three elements has the smallest radius? Justify your reasoning.

.....

.....

.....

.....

.....

.....

.....

.....

- d) Give the electron configuration of beryllium.

.....

.....

Marker use

2

1

3

1

Total Q1

7

Question 2

The element francium is found in nature, but in extremely small quantities. It is estimated that only 20 – 30 g exists at any one time in the Earth’s crust.

Its most stable isotope, Fr-223 ($^{223}_{87}\text{Fr}$), exists on Earth for only short periods. Below is a decay graph of the isotope Fr-223.

Decay Graph for Francium-223

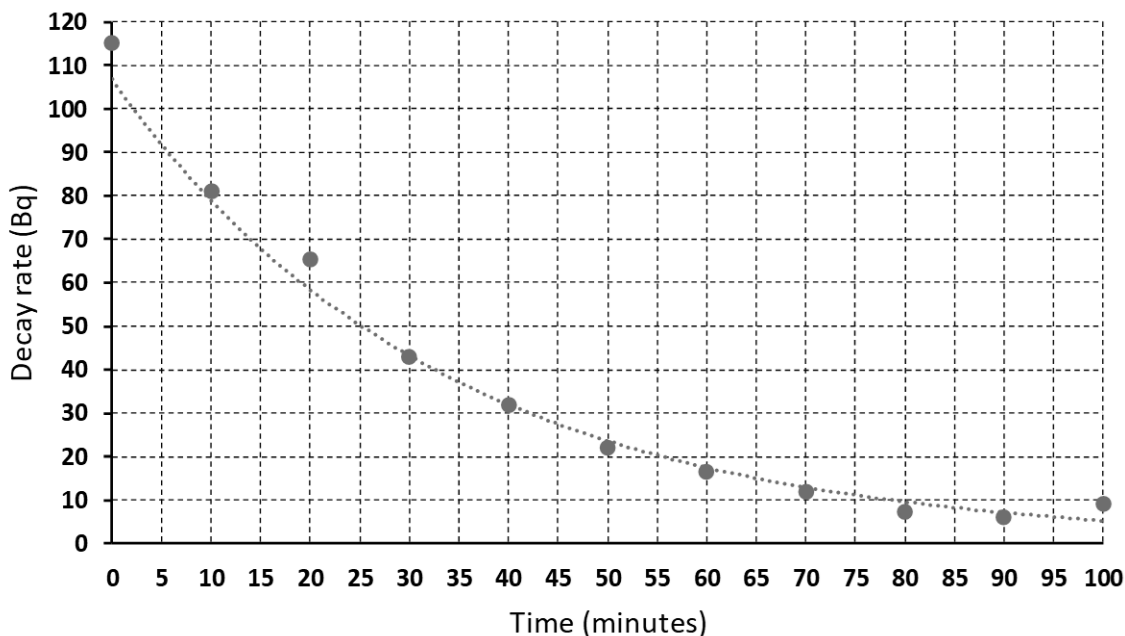

a) From the chart determine the half-life of Fr-223.

2

.....

.....

.....

.....

b) Account for the variation in the decay rate from the expected trend line.

1

.....

.....

c) If Fr-223 decays so rapidly, how is it possible that any Fr-223 exists in the Earth’s crust at all?

1

.....

.....

Question 2 continues

Question 2 continued

Marker use

- d) Fr-223 decays by beta decay. Write the decay equation for Fr-223, clearly indicating what isotope is formed from the beta decay.

2

.....

.....

.....

.....

Total Q2

Section A continues

6

Question 3

Over the past two decades, radioimmunotherapy has been used to effectively treat many types of cancer. The treatment involves injecting cancer patients with a radioactive chemical that selectively attaches to tumour cells located throughout the body.

One method injects a radium-223 ($^{223}_{88}\text{Ra}$) chemical into the patient. Ra-223 is an **alpha** emitter.

a) Write a decay equation for Ra-223.

2

.....
.....
.....
.....

Another method for treating different tumours involves injecting a beta emitter into the patient, forming the isotope osmium-188 ($^{188}_{76}\text{Os}$).

b) Write a decay equation for the formation of Os-188 via **beta** decay.

2

.....
.....
.....
.....

c) Both alpha and beta radioimmunotherapy are very effective at killing tumours. Considering the ionisation and penetration of alpha and beta radiation, outline the advantages of each treatment.

4

.....
.....
.....
.....
.....
.....
.....
.....
.....
.....

Question 3 continues

Question 3 continued

Marker use

- d) What dangers exist for a patient that has been injected with a radioactive isotope, be it an alpha or beta emitter?

1

.....
.....

Beta decay events also often emit gamma radiation via a metastable intermediate.

- e) What use can be made of gamma radiation during radioimmunotherapy? Justify your reasoning from the properties of gamma radiation.

2

.....
.....
.....
.....

Total Q3

Section A continues

11

Section A continued

Marker use

Question 4

Nuclear reactors have been used to produce electrical energy around the world for over 50 years. The reaction involves the bombardment of U-235 with a neutron producing a **chain reaction** that is controlled to produce heat and, subsequently, electricity.

a) Complete the fission reaction by adding the correct isotope into the empty box below.

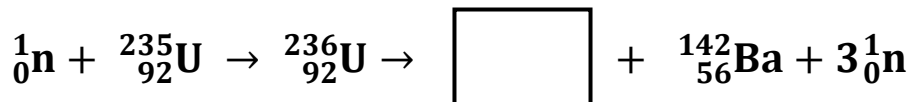

Spare diagram used (✓)

1

b) What is meant by a chain reaction?

1

.....

.....

.....

c) The isotope Ba-142 has a half-life of 10.5 minutes. If a sample has an activity of 1.28 MBq, what will the activity of the sample be after 63 minutes? Give your answer in kBq.

3

.....

.....

.....

.....

.....

.....

.....

d) If the activity of Ba-142 is 1.28 MBq, what was its activity 21 minutes earlier?

1

.....

.....

Question 4 continues

Question 4 continued

Marker use

e) Suggest **two (2)** sources of natural background radiation.

1

.....

.....

Total Q4

Section A continues

7

Question 5

A single carbon-12 atom has a mass of 1.993×10^{-23} g. It has a relative mass of exactly 12 atomic mass units.

- a) The weighted mass of a chlorine atom over its two isotopes is 5.888×10^{-23} g. Show that its relative atomic mass is 35.45 .

/ 2

.....

.....

.....

.....

.....

.....

.....

- b) Chlorine has two isotopes, Cl-35 and Cl-37. From the relative atomic mass, calculate the percentage of each isotope present in naturally occurring chlorine.

/ 3

.....

.....

.....

.....

.....

.....

.....

.....

.....

Total Q5

/ 5

Spare Diagrams

Question 1 a)

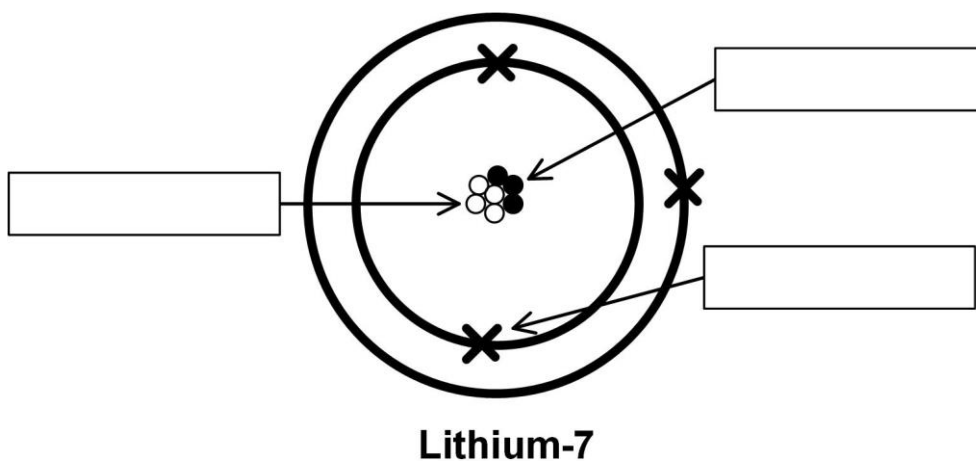

Question 4 a)

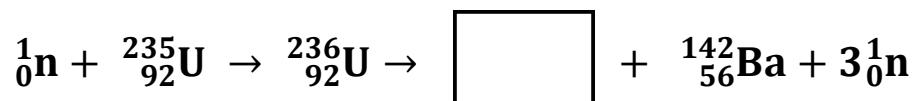

End of Section A



OFFICE OF TASMANIAN
ASSESSMENT, STANDARDS
& CERTIFICATION

This exam paper and any materials associated with this exam
(including answer booklets, cover sheets, rough note paper, or information sheets)
remain the property of the Office of Tasmanian Assessment, Standards and Certification.



Attach your candidate label here

External Assessment 2022

PHYSICAL SCIENCES

PSC315118

Section **B**

| | |
|-------------------|----|
| Pages | 12 |
| Questions | 5 |
| Information Sheet | 1 |

Suggested working time: 36 minutes

Instructions:

- Answer **all** questions and **all** items within each question.
- Write your answers in the spaces provided in this exam paper.
 - Show working in answers to numerical questions and use appropriate units. Marks may not be given to answers without working.
 - Spare diagrams have been provided at the end of each section. Indicate in the box provided if you have used the spare diagrams.
- The exam is **three (3)** hours in length. It is suggested that you spend **approximately 36 minutes** in total answering the questions in this section.
- A TASC approved scientific calculator is allowed throughout the exam.
- The **Physical Sciences Information Sheet** can be used throughout the exam.
- All answers must be written in **English**.
- You **must** make sure your answers address:
 - Criterion 5 apply concepts and processes of motion and force.

| Marker Use | |
|------------|------|
| C5 | / 36 |

Guide to Exam Structure

| | Questions available | Questions to answer | Suggested working time | Marks available |
|------------------|---------------------|---------------------|----------------------------------|------------------|
| Section A | 5 | 5 | 36 minutes | 36 marks |
| Section B | 5 | 5 | 36 minutes | 36 marks |
| Section C | 5 | 5 | 36 minutes | 36 marks |
| Section D | 5 | 5 | 36 minutes | 36 marks |
| Section E | 5 | 5 | 36 minutes | 36 marks |
| Totals | 25 | 25 | 180 minutes (3 hours) | 180 marks |

Question 6

Marker use

A helicopter was dispatched from the Hobart Airport and travelled directly North to Tunbridge, a distance of 78 km, in a time of 36 minutes. It then turned directly West, travelling 100 km to the town of Derwent Bridge, taking a further 40 minutes.

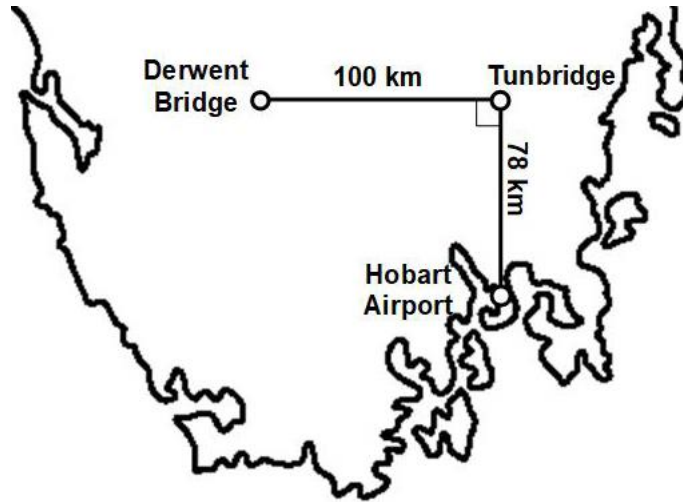

a) What distance was travelled by the helicopter?

.....
.....

1

b) What is the helicopter's displacement for the whole journey?

.....
.....
.....
.....
.....
.....
.....
.....

3

c) What velocity would the helicopter need if it was to return to Hobart in 30 minutes.

.....
.....
.....
.....

2

Total Q6

Section B continues

6

Question 7

Cross-country skiing is a form of skiing where skiers rely on their own locomotion to move across a snow-covered field.

A cross-country skier at the recent winter Beijing Olympics completed the 15.0 km course in 0.632 hours.

- a) Calculate the average speed of the skier for the race in km h^{-1} .

/ 1

.....

.....

- b) Calculate the average speed of the skier in m s^{-1} .

/ 1

.....

.....

A graph showing the velocity of the skier for a short period of time is displayed below.

Cross-country Skier Velocity vs Time Recording

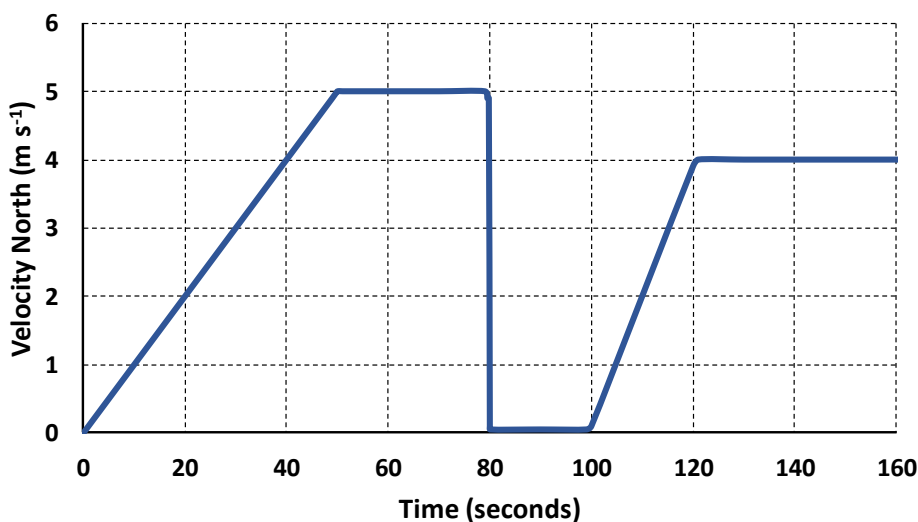

- c) At what time interval(s) was the skier stationary?

/ 1

.....

.....

- d) What was the total distance covered by the skier in the 160 second recording?

/ 2

.....

.....

.....

.....

Question 7 continues

Question 7 continued

Marker use

e) What is the acceleration of the skier in the first 40 seconds?

1

.....

.....

.....

.....

Total Q7

6

Section B continues

Section B continued

Marker use

Question 8

An electric car with a mass of 1850 kg is travelling at 10 m s^{-1} North. It accelerates at 2.5 m s^{-2} North for 10 seconds.

a) Calculate the final velocity of the car.

2

.....
.....
.....
.....

b) What displacement did the car travel during this time?

2

.....
.....
.....
.....

c) What is the weight of the car?

1

.....
.....

d) On the diagram below, sketch the forces on the car during the acceleration. Assume no friction exists.

3

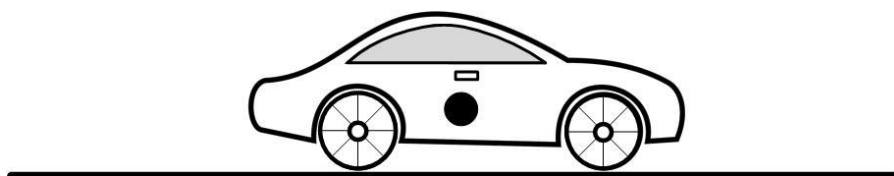

Spare diagram used (✓)

Question 8 continues

Question 8 continued

Marker use

- e) During the acceleration, the driver of the car noticed she felt pushed back in her seat. Use one of Newton's laws to explain this phenomenon.

2

.....

.....

.....

.....

.....

.....

Total Q8

10

Section B continues

Question 9

A rock is thrown vertically into the air from a height of 1.60 m above the ground with a velocity of 24.8 m s⁻¹ upwards.

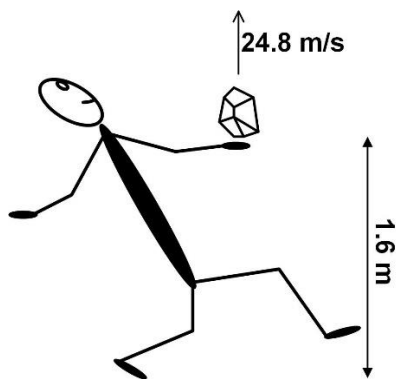

a) Calculate the maximum height above the ground reached by the rock.

2

.....
.....
.....
.....

b) Calculate the time until the rock impacts the ground after being thrown into the air.

3

.....
.....
.....
.....
.....
.....

Question 9 continues

Question 9 continued

Marker use

In a similar experiment, the rock is replaced with a light ball of the same size. The ball rises a smaller distance before falling and quickly reaching its terminal velocity.

c) What is meant by terminal velocity?

1

.....
.....
.....
.....

d) In this situation, why does the ball reach terminal velocity so rapidly, yet the rock appears to be affected by gravity alone?

1

.....
.....

Total Q9

Section B continues

7

Question 10

A netball player throws a ball horizontally towards a teammate standing 12 m away. The ball is thrown from a height of 2.1 m. The teammate catches the ball at waist height of 0.90 m.

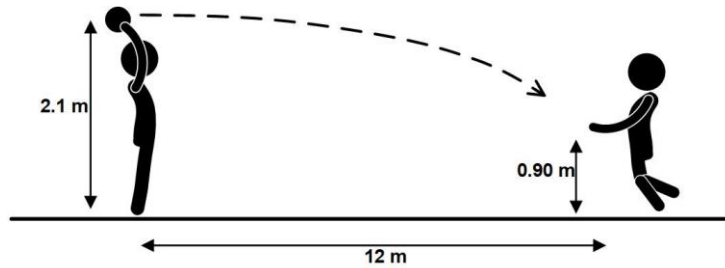

a) Show that the ball was in the air for about 0.5 seconds.

2

.....

.....

.....

.....

b) Calculate the initial horizontal velocity of the ball.

2

.....

.....

.....

.....

c) What final velocity did the ball have when caught by the teammate?

3

.....

.....

.....

.....

.....

Total Q10

7

Spare Diagram

Question 8 d)

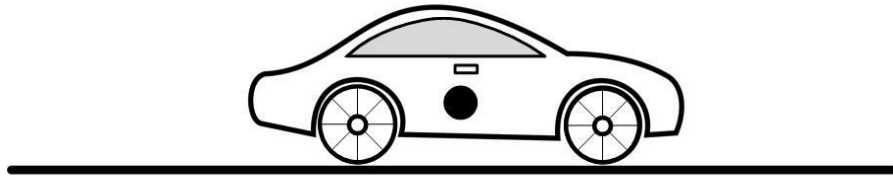

End of Section B



OFFICE OF TASMANIAN
ASSESSMENT, STANDARDS
& CERTIFICATION

This exam paper and any materials associated with this exam
(including answer booklets, cover sheets, rough note paper, or information sheets)
remain the property of the Office of Tasmanian Assessment, Standards and Certification.

External Assessment 2022

PHYSICAL SCIENCES

PSC315118

Section **C**

| | |
|-------------------|----|
| Pages | 12 |
| Questions | 5 |
| Information Sheet | 1 |

Suggested working time: 36 minutes

Instructions:

- Answer **all** questions and **all** items within each question.
- Write your answers in the spaces provided in this exam paper.
 - Show working in answers to numerical questions and use appropriate units. Marks may not be given to answers without working.
 - Spare diagrams have been provided at the end of each section. Indicate in the box provided if you have used the spare diagrams.
- The exam is **three (3)** hours in length. It is suggested that you spend **approximately 36 minutes** in total answering the questions in this section.
- A TASC approved scientific calculator is allowed throughout the exam.
- The **Physical Sciences Information Sheet** can be used throughout the exam.
- All answers must be written in **English**.
- You **must** make sure your answers address:
 - Criterion 6 apply concepts and processes of conservation in physics.

| Marker Use | |
|------------|------|
| C6 | / 36 |

Guide to Exam Structure

| | Questions available | Questions to answer | Suggested working time | Marks available |
|------------------|---------------------|---------------------|----------------------------------|------------------|
| Section A | 5 | 5 | 36 minutes | 36 marks |
| Section B | 5 | 5 | 36 minutes | 36 marks |
| Section C | 5 | 5 | 36 minutes | 36 marks |
| Section D | 5 | 5 | 36 minutes | 36 marks |
| Section E | 5 | 5 | 36 minutes | 36 marks |
| Totals | 25 | 25 | 180 minutes (3 hours) | 180 marks |

Question 11

A 74.5 kg skier is stationary at the top of a 145 m long ski run that has a vertical height of 32.1 m.

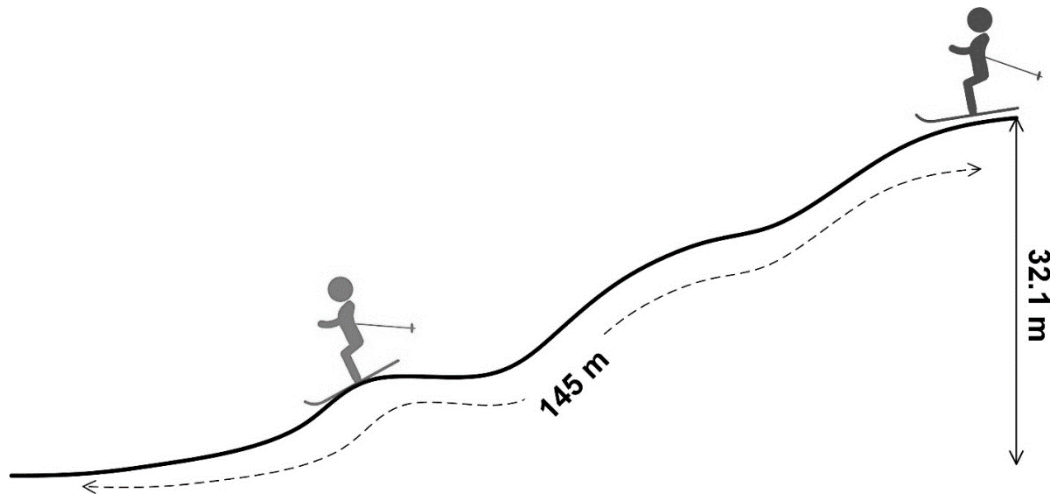

a) Calculate the skier's potential energy at the top of the ski run.

/ 2

.....
.....
.....
.....

b) If the slope was frictionless, what is the skier's kinetic energy at the bottom of the run?

/ 1

.....
.....

The slope is not frictionless and the skier's speed was measured at the bottom of the run to be only 18.0 m s⁻¹.

c) Calculate the work done by friction on the skier .

/ 2

.....
.....
.....
.....

d) Calculate the magnitude of the average frictional force on the skier.

/ 1

.....
.....
.....
.....

Total Q11

/ 6

Question 12

One method used to generate energy is hydroelectric power, where water is collected in high elevation dams and run through low lying electrical generators or turbines.

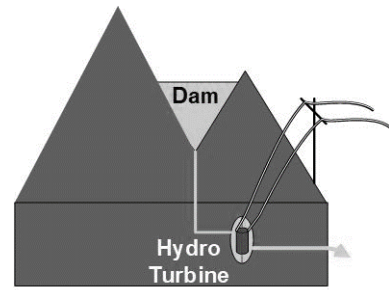

Marker use

A dam in Tasmania stores 1.8×10^9 kg water every **24 hours**. This is released into a turbine 180 m below the dam.

a) What is the theoretical amount of electrical energy that can be generated in 24 hours.

2

.....
.....
.....
.....

b) When the 1.8×10^9 kg of water drops the 180 m to the generator, it is found to create 1.43 TJ of electrical energy. Calculate the percentage of gravitational potential energy changed to electrical energy.

1

.....
.....

c) Calculate the power output from the turbine.

2

.....
.....
.....
.....

Question 12 continues

Question 12 continued

Marker use

Another method of generating reliable energy is wind turbines combined with pumped hydroelectric storage.

The image below outlines the process where a wind turbine powers a water pump, which is used to fill an elevated dam.

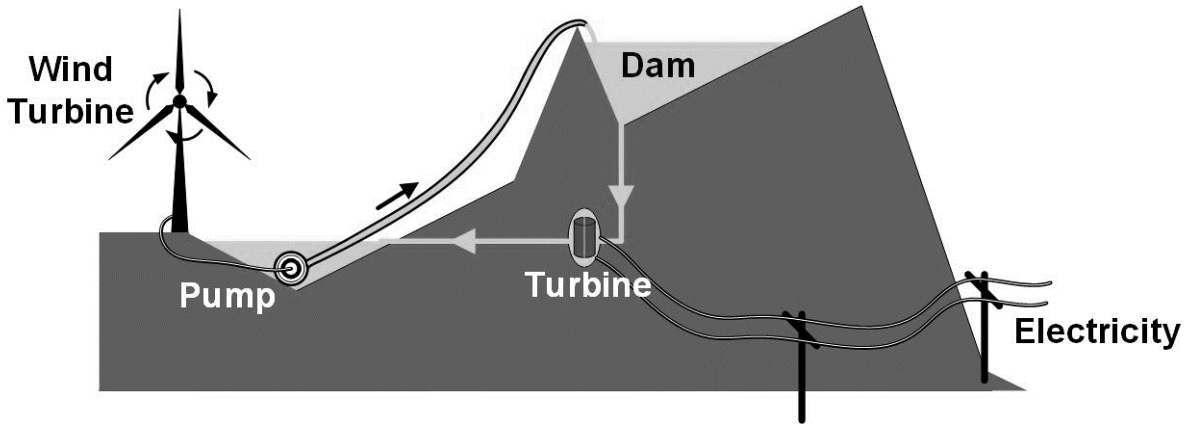

d) What energy changes are occurring in this pumped hydroelectric system.

2

.....

.....

.....

.....

.....

.....

.....

Total Q12

Section C continues

7

Question 13

a) Using circuit notation, sketch a circuit showing a battery connected to a resistor. A current flows through the resistor. Include a voltmeter and ammeter in the circuit to correctly read the voltage across, and current through, the resistor.

2

b) In the circuit you have designed, if you used a 1.5 V battery and a 6.0 ohm resistor, what is the reading on the:

2

i. Voltmeter:

.....

.....

ii. Ammeter:

.....

.....

The circuit design for room lighting in a house is displayed below. A 9.0 watt light bulb is used.

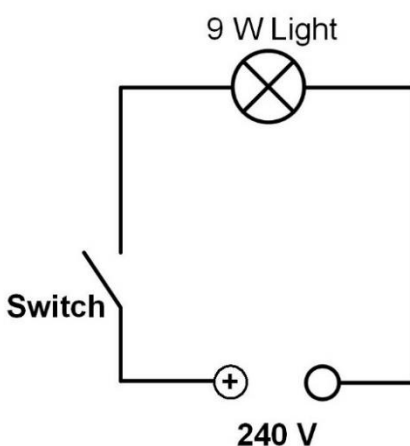

c) If the power supply in Australia is 240 V, calculate the resistance of the 9.0 W light bulb.

1

.....

.....

Question 13 continues

Question 13 continued

Marker use

The homeowner wants to add a second light bulb in parallel to make the total light power output 20 W.

d) Calculate the resistance of the second light bulb.

3

.....

.....

.....

.....

.....

.....

e) If electrical energy costs 24.697 c per kWh, calculate the cost of running the 20 W light system for one full day. Give your answer to the nearest cent.

2

.....

.....

.....

.....

Total Q13

10

Section C continues

Question 14

There are many different types of diodes that are placed in circuits. One common type is the LED, Light Emitting Diode.

These diodes come in a range of colours and their non-ohmic electrical behaviour is important in electronic devices. To illustrate this, a graph of I vs V for Red, Green and Blue LED's is displayed below.

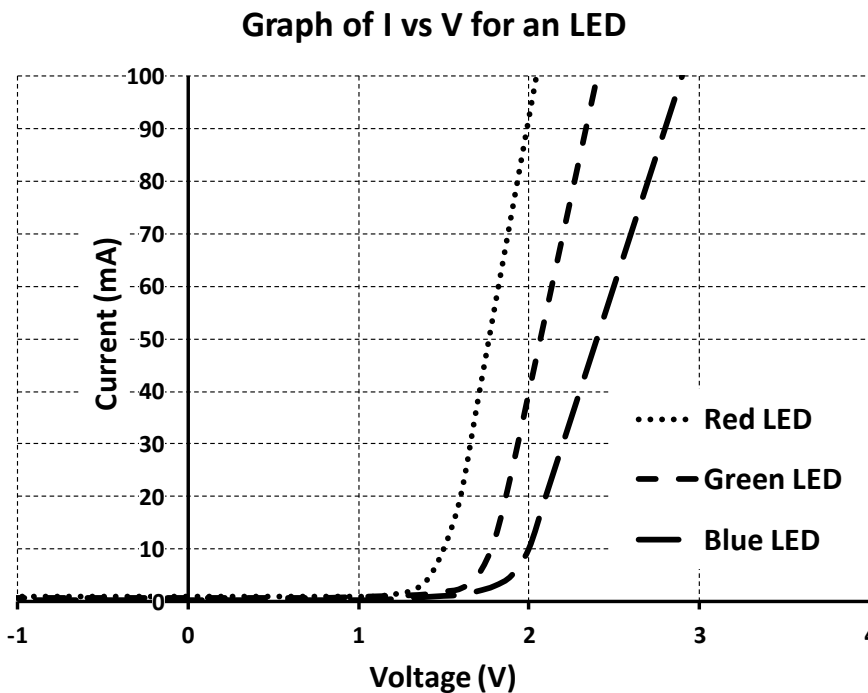

a) At 2.0 volts, what current passes through the Red LED?

.....

.....

1

b) Given your answer to (a), what charge passes through the Red diode at 2.0 V in 1.0 second?

.....

.....

1

c) How many electrons does this represent?

.....

.....

1

Question 14 continues

Question 14 continued

Marker use

d) LED's are non-ohmic resistors. What aspect of the graph suggests that the Red LED is non-ohmic?

1

.....
.....
.....

e) At a potential difference of 2.0 V, which of the three coloured diodes has the greatest resistance? Explain your reasoning.

2

.....
.....
.....
.....

Total Q14

Section C continues

6

Section C continued

Marker use

Question 15

During a game of rugby league, a 98 kg ball carrier running **northward** at 3.7 m s^{-1} is tackled by an 84 kg opponent tackler running **south** at 4.8 m s^{-1} . The pair collide and are held together during the encounter.

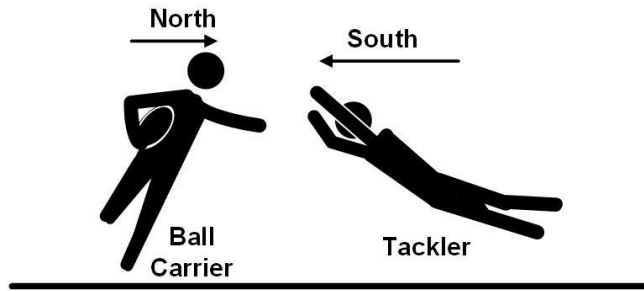

a) Calculate the momentum of each of the ball carrier and the tackler before the collision.

2

i. Ball carrier:

.....

ii. Tackler:

.....

b) Calculate the velocity of the combined players after the collision.

2

.....

.....

.....

c)

3

i. Calculate the total kinetic energy of the two players before the collision.

.....

.....

ii. Calculate the kinetic energy of the combined players after the collision.

.....

.....

iii. Is this an elastic collision? Justify your answer.

.....

.....

Total Q15

7

Blank Page

End of Section C



OFFICE OF TASMANIAN
ASSESSMENT, STANDARDS
& CERTIFICATION

This exam paper and any materials associated with this exam
(including answer booklets, cover sheets, rough note paper, or information sheets)
remain the property of the Office of Tasmanian Assessment, Standards and Certification.

External Assessment 2022

PHYSICAL SCIENCES

PSC315118

Section **D**

| | |
|-------------------|----|
| Pages | 12 |
| Questions | 5 |
| Information Sheet | 1 |

Suggested working time: 36 minutes

Instructions:

- Answer **all** questions and **all** items within each question.
- Write your answers in the spaces provided in this exam paper.
 - Show working in answers to numerical questions and use appropriate units. Marks may not be given to answers without working.
 - Spare diagrams have been provided at the end of each section. Indicate in the box provided if you have used the spare diagrams.
- The exam is **three (3)** hours in length. It is suggested that you spend **approximately 36 minutes** in total answering the questions in this section.
- A TASC approved scientific calculator is allowed throughout the exam.
- The **Physical Sciences Information Sheet** can be used throughout the exam.
- All answers must be written in **English**.
- You **must** make sure your answers address:
 - Criterion 7 apply concepts and processes of chemical structures and properties.

| Marker Use | |
|------------|------|
| C7 | / 36 |

Guide to Exam Structure

| | Questions available | Questions to answer | Suggested working time | Marks available |
|------------------|---------------------|---------------------|----------------------------------|------------------|
| Section A | 5 | 5 | 36 minutes | 36 marks |
| Section B | 5 | 5 | 36 minutes | 36 marks |
| Section C | 5 | 5 | 36 minutes | 36 marks |
| Section D | 5 | 5 | 36 minutes | 36 marks |
| Section E | 5 | 5 | 36 minutes | 36 marks |
| Totals | 25 | 25 | 180 minutes (3 hours) | 180 marks |

Question 16

Marker use

a) Give the systematic name of the following compounds:

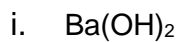

.....

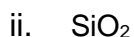

.....

b) Give the chemical formula of the following compounds:

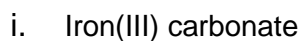

.....



.....

c) Draw the structure of 3-bromopent-1-yne.

d) Give the systematic name for the following compound.

.....

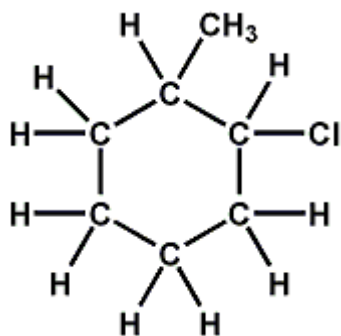

Total Q16

Section D continues

Question 17

The elements hydrogen (H₂), nitrogen (N₂), oxygen (O₂), fluorine (F₂) and chlorine (Cl₂) are all diatomic gaseous elements at room temperature.

a) Which of the element(s) has similar chemical properties to sulfur?

.....
.....

/ 1

b) Which of the five diatomic elements are in the same group on the Periodic Table?

.....
.....

/ 1

c) Which of the above element(s) readily form -1 ions?

.....
.....

/ 1

d) Which of these gaseous elements can be identified using the pop test?

.....
.....

/ 1

Like many of these elements, combining them into molecular compounds changes their physical properties. For example, gaseous H₂ and O₂ combine chemically to form water H₂O.

e) Sketch the electron dot diagram for

i. H₂

ii. O₂

iii. H₂O

/ 3

Question 17 continues

Question 17 continued

Marker use

- f) The intramolecular bond strengths between atoms in each of H_2 , O_2 and H_2O are similar in strength. Yet water is a liquid at room temperature and H_2 and O_2 are both gases under the same conditions. With the aid of a diagram, explain this difference.

3

.....

.....

.....

.....

.....

.....

Total Q17

10

Section D continues

Section D continued

Marker use

Question 18

The chemical but-1-ene has the structure.

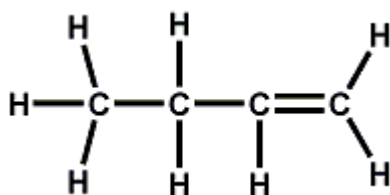

a) To which homologous group does but-1-ene belong?

.....
.....

/ 1

b) Sketch an isomer of but-1-ene that is saturated.

/ 1

c) But-1-ene readily decolours bromine via an addition reaction. Give a balanced equation using **structural formula**.

/ 2

d) But-1-ene is a highly flammable gas. Write a balanced combustion reaction with **insufficient** oxygen using **molecular formulae**.

/ 2

.....
.....
.....
.....

Question 18 continues

Question 18 continued

- e) Complete the reaction sequence displayed below by sketching the structural formula for (i) and the reaction's conditions (ii).

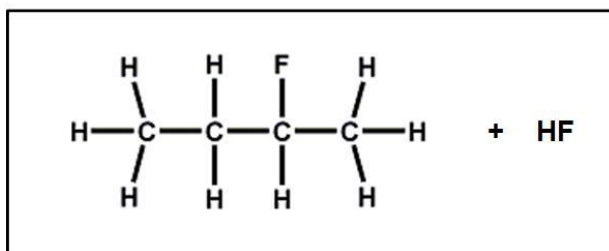
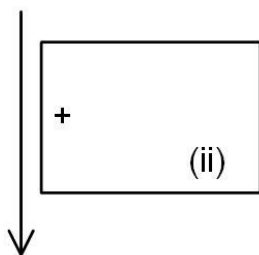
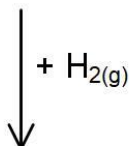
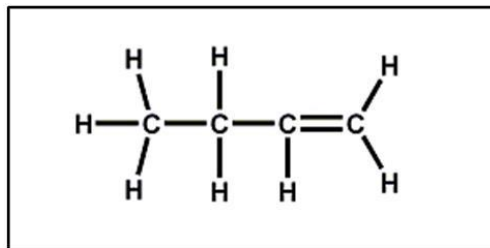

Marker use

2

Spare diagram used (✓)

Total Q18

8

Section D continues

Question 19

Sodium is a malleable and electrically conductive metal.

- a) Describe the bonding in metallic sodium using a diagram to assist, that explains its properties of electrical conductivity and malleability .

3

.....

.....

.....

.....

- b) With the aid of an electron shell diagram, describe how sodium chloride forms.

3

.....

.....

.....

.....

.....

.....

Question 19 continues

Question 19 continues

Marker use

c) Solutions of NaCl (saltwater) are difficult to identify as they are colourless.

i. Outline a **chemical test** that can be used to identify the presence of Cl⁻ in saltwater.

/ 2

.....
.....
.....
.....

ii. **Name** a test that can be used to identify the presence of Na⁺ in saltwater.

/ 1

.....
.....

Total Q19

Section D continues

/ 9

Section D continued

Marker use

Question 20

Graphite is an allotrope of carbon. It is soft and does conduct electricity. With the aid of a diagram outline the structure of graphite and explain why it is **soft** and **conductive**.

3

.....

.....

.....

.....

.....

.....

Total Q20

3

Spare Diagram

Question 18 e)

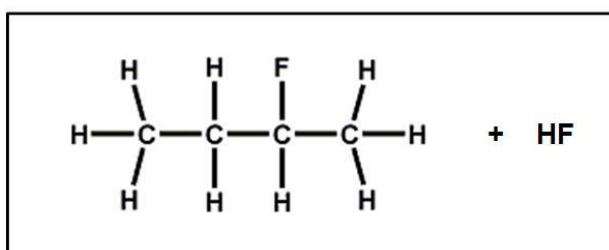
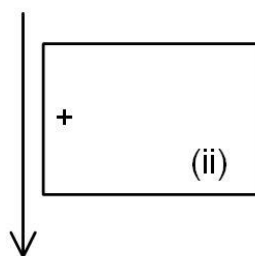
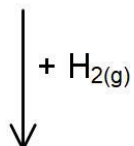
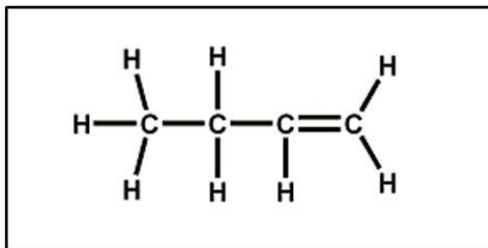

End of Section D



OFFICE OF TASMANIAN
ASSESSMENT, STANDARDS
& CERTIFICATION

This exam paper and any materials associated with this exam
(including answer booklets, cover sheets, rough note paper, or information sheets)
remain the property of the Office of Tasmanian Assessment, Standards and Certification.

External Assessment 2022

PHYSICAL SCIENCES

PSC315118

Section **E**

| | |
|-------------------|----|
| Pages | 12 |
| Questions | 5 |
| Information Sheet | 1 |

Suggested working time: 36 minutes

Instructions:

- Answer **all** questions and **all** items within each question.
- Write your answers in the spaces provided in this exam paper.
 - Show working in answers to numerical questions and use appropriate units. Marks may not be given to answers without working.
 - Spare diagrams have been provided at the end of each section. Indicate in the box provided if you have used the spare diagrams.
- The exam is **three (3)** hours in length. It is suggested that you spend **approximately 36 minutes** in total answering the questions in this section.
- A TASC approved scientific calculator is allowed throughout the exam.
- The **Physical Sciences Information Sheet** can be used throughout the exam.
- All answers must be written in **English**.
- You **must** make sure your answers address:
 - Criterion 8 apply concepts and processes of chemical reactions and reacting quantities.

| Marker Use | |
|------------|------|
| C8 | / 36 |

Blank Page

Guide to Exam Structure

| | Questions available | Questions to answer | Suggested working time | Marks available |
|------------------|---------------------|---------------------|----------------------------------|------------------|
| Section A | 5 | 5 | 36 minutes | 36 marks |
| Section B | 5 | 5 | 36 minutes | 36 marks |
| Section C | 5 | 5 | 36 minutes | 36 marks |
| Section D | 5 | 5 | 36 minutes | 36 marks |
| Section E | 5 | 5 | 36 minutes | 36 marks |
| Totals | 25 | 25 | 180 minutes (3 hours) | 180 marks |

Question 21

Marker use

Ammonium chloride is a white crystalline compound with the formula NH_4Cl .

a) Show that the molar mass of NH_4Cl is 53.49 g mol^{-1} .

2

.....
.....
.....
.....

b) Show that 22.1 g of NH_4Cl represents 0.413 moles.

1

.....
.....

c) Find the number of **atoms** in 0.413 moles of NH_4Cl .

2

.....
.....
.....
.....

d) What is the concentration of NH_4Cl solution if 0.413 moles of solid NH_4Cl is placed in a 50.0 mL volumetric flask and made up to the mark with water? Provide your answer in both **mol L⁻¹** and **g L⁻¹**.

3

.....
.....
.....
.....
.....
.....

Total Q21

8

Section E continues

Question 22

A, B and C are hypothetical compounds. The following reaction takes place to form the solid C.

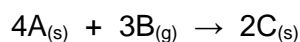

- a) When 25 g of A was reacted with B, 48 g of C was produced. What **mass** of B was reacted?

.....
.....

1

- b) If 0.415 moles of A was reacted with B, how many **moles** of C will be produced?

.....
.....
.....
.....

1

A real reaction, where aluminium is burnt in oxygen to form aluminium oxide is shown below.

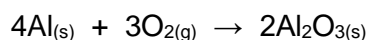

- c) What mass of $Al_2O_{3(s)}$ will form from 89 g of $Al_{(s)}$?

.....
.....
.....
.....
.....
.....
.....
.....
.....

4

Total Q22

6

Section E continues

Question 23

A chemical found in the skin of green potatoes was analysed. The results were as follows:

Hydrogen = 2.24 %

Carbon = 26.7 %

Oxygen = 71.1 %.

- a) Use this information to **show** that the compound has an empirical formula, HCO_2 .

.....

.....

.....

.....

.....

.....

.....

.....

.....

.....

/ 4

- b) The compound was further analysed to find its molar mass, which is 90.03 g mol^{-1} . Use this information to **show** that the chemical compound is oxalic acid, $\text{H}_2\text{C}_2\text{O}_4$.

.....

.....

/ 1

- c) Oxalic acid is considered a weak acid.

- i. What is meant by 'a weak acid'?

.....

.....

/ 1

- ii. Suggest a pH of a dilute oxalic acid solution.

.....

.....

/ 1

Total Q23

Section E continues

/ 7

Question 24

The concentration of hydrochloric acid (HCl) is easily determined by titration against anhydrous sodium carbonate (Na_2CO_3 , $M_r = 105.99 \text{ g mol}^{-1}$).

- a) Write a balanced equation for the reaction of a dilute HCl solution with a solution of Na_2CO_3 .

.....
.....
.....

2

0.373 g of Na_2CO_3 was placed in a conical beaker and dissolved in water.

3 drops of acid-base indicator were added.

When titrated against an unknown HCl acid solution the Na_2CO_3 was exactly neutralised by 28.4 mL of the acid.

- b) Show that the concentration of the unknown HCl is about 0.25 mol L^{-1} .

.....
.....
.....
.....
.....
.....

3

- c) Calculate the volume of water needed to be added to 1.0 L of 0.25 mol L^{-1} HCl to create a 0.20 mol L^{-1} solution.

.....
.....
.....
.....

2

Total Q24

Section E continues

7

Question 25

The strong acid, hydrobromic acid ($\text{HBr}_{(\text{aq})}$) was reacted with sodium hydroxide (NaOH) and magnesium metal (Mg).

- a) $\text{HBr}_{(\text{aq})}$ was added to $\text{NaOH}_{(\text{aq})}$. Write a chemical equation that could represent the reaction occurring.

/ 2

.....

.....

.....

.....

- b) By referring to the Brønsted-Lowry model of acids and bases, explain the relationship that exists between an acid like HBr when reacted with a base like NaOH .

/ 3

.....

.....

.....

.....

.....

.....

- c) A 1.0 mol L^{-1} solution of HBr was also added to a strip of magnesium metal.

- i. Write a chemical equation that would represent the reaction.

/ 2

.....

.....

- ii. From your equation, outline **two (2)** observations from the reaction.

/ 1

.....

.....

Total Q25

/ 8

Blank Page

End of Section E

Blank Page

Blank Page



OFFICE OF TASMANIAN
ASSESSMENT, STANDARDS
& CERTIFICATION

This exam paper and any materials associated with this exam
(including answer booklets, cover sheets, rough note paper, or information sheets)
remain the property of the Office of Tasmanian Assessment, Standards and Certification.